

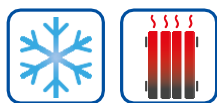

Serbatoi per accumulo di acqua da riscaldamento e/o refrigerata.



Caratteristiche principali

Materiale	Acciaio al carbonio	
Trattamento interno	Grezzo	
Pressione massima di esercizio	6 bar	
Temperatura minima di esercizio	Refrigerazione	6 °C
Temperatura massima di esercizio	Riscaldamento	95 °C
Garanzia	Serbatoio	5 anni

Accessori

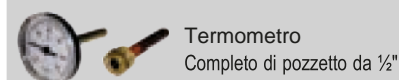

Accessori (solo per modello HC 100)



Modello	Utilizzo	Isolamento	Classe energetica UE 812/2013	Dispersione (W)	Volume nominale (l)	Peso (kg)
HC 100		PU 50mm + PVC	B	41	107	29
HC 200		PU 50mm + PVC	B	61	205	48
HC 300		PU 50mm + PVC	B	68	290	59
HC 400		PU 50mm + PVC	C	78	405	76
HC 500		PU 50mm + PVC	C	92	490	85

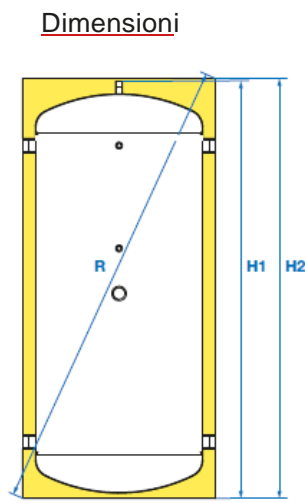
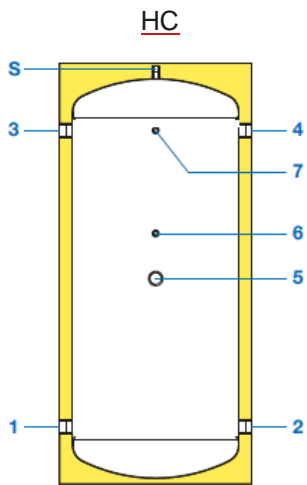

Legenda		
1	Attacco idraulico	1" ½
2	Attacco idraulico	1" ½
3	Attacco idraulico	1" ½
4	Attacco idraulico	1" ½
5	Resistenza elettrica	1" ½
6	Sonda	½"
7	Termometro	½"
S	Sfiato o valvola di sicurezza	½"
<hr/>		
Ø D1	Diametro senza isolamento	
Ø D2	Diametro con isolamento	
R	Ribaltamento	
H1	Altezza senza isolamento	
H2	Altezza con isolamento	

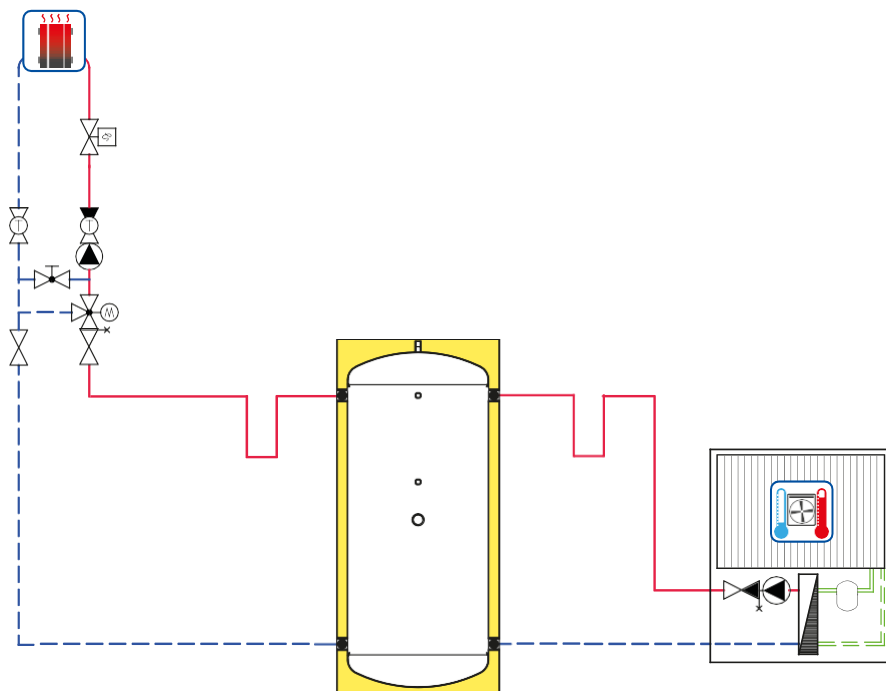
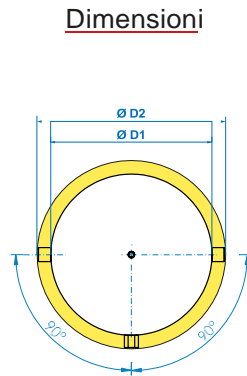

Modello	1-5	3-4	5	6	7	Ø D1	Ø D2	R	H1	H2
100	190	740	465	560	740	400	500	1074	924	951
200	210	960	585	715	960	500	600	1332	1184	1189
300	210	1110	660	810	1110	550	650	1500	1344	1352
400	221	1121	671	821	1121	650	750	1563	1370	1371
500	221	1371	796	971	1371	650	750	1795	1620	1631