

LUNA 2T

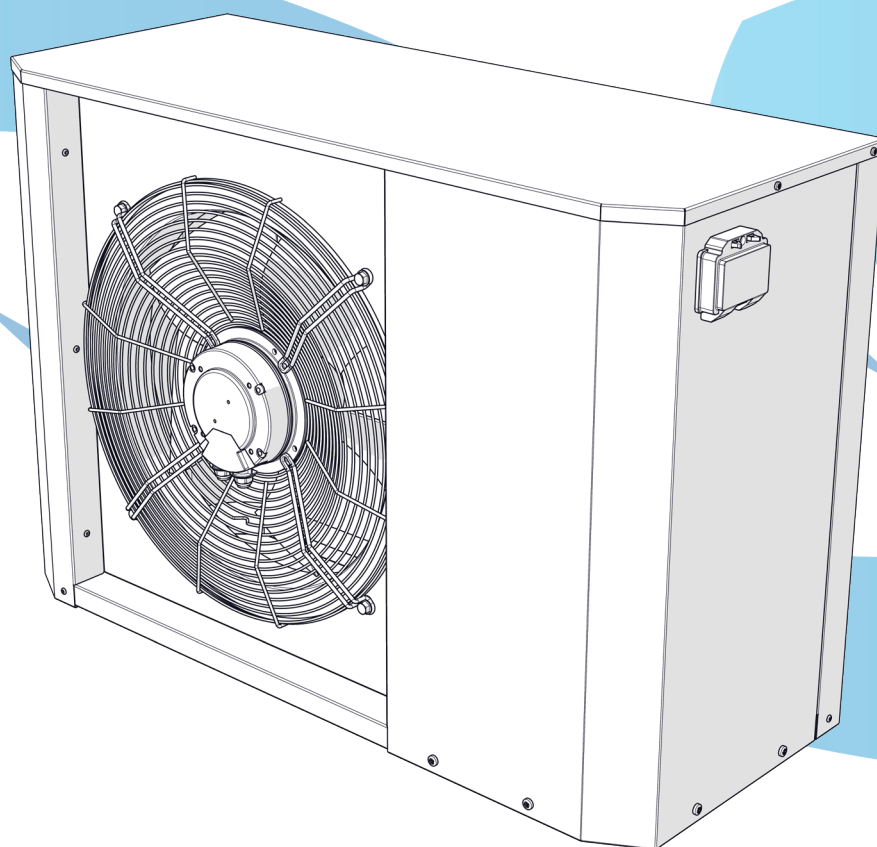

Reversible heat pump with inverter technology

The page features several large, overlapping, wavy shapes in various shades of blue, creating a modern, abstract background. These shapes are positioned primarily in the lower half and right side of the page, framing the text.

Dear Customer,

Thank you for choosing a Thermics energie machine, an innovative, modern and quality product that will ensure your well-being, silence operation and safety for a long time.

This instruction manual contains important indications and suggestions that must be observed in order to make the installation and use of the machine as easy as possible.

Thank you again.
Thermics energie

CONTENTS

1	Introduction	5
1.1	Purpose of the manual	5
1.2	Symbols	7
1.3	General warnings	8
2	Safety regulations	10
2.1	General safety rules	10
2.2	Security pictograms	11
3	Reception and handling	12
3.1	Handling with packaging	12
3.2	Verification of packaging	14
3.3	Packaging content	15
3.4	Removing the packaging	16
3.5	Handling without packaging	17
4	Mounting	18
4.1	Recommended equipment	18
4.2	System inspection	19
4.3	Verification of functional spaces	20
4.4	Unit positioning	21
4.5	Noise control	22
4.6	Where not to install	22
4.7	Recommendations and suggestions	23
4.8	Access to internal parts	24
4.9	Hydraulic diagrams	27
4.10	Machine connections	28
4.11	Hydraulic connection	30
4.12	Connecting the condensate drain	33
4.13	Power supply connection	36

4.14 Duct characteristics

41

5 Commissioning

42

5.1 Preliminary checks

42



1 Introduction

1.1 Purpose of the manual

The purpose of this manual is to provide the customer with all the information necessary to use and operate the machine correctly, independently and safely.

The manual contains information on the safety, technical aspects, operation, maintenance and transport of the following machines:

LUNA 2T - Reversible heat pump with inverter technology

Correct use and maintenance contribute to good operation and a longer life cycle of the machine.

For any doubt or further information, please contact your nearest service centre or the manufacturer's after-sales service directly.

1.1.1 Storage

The manual must be kept with care and in the immediate vicinity of the machine, far from liquids and anything else that could compromise its readability, and must be available for consultation at any time. The manual and the Declaration of Conformity are an integral part of the machine and must therefore accompany it throughout its entire life cycle.

Parts of this documents must not be removed, torn or arbitrarily modified.

If the manual is lost or illegible, request a copy to the Manufacturer.

1.1.2 Updating the manual

The information, descriptions and illustrations contained in this manual reflect the state of the art at the time the machine was placed on the market.

The Manufacturer, in its constant commitment to improve its products and/or for market reasons, reserves the right to make, at any time, modifications to the machines for technical or commercial reasons without prior notice and without legitimising the Purchaser to terminate the contract.

In the event that, due to modifications to the machine installed at the Customer's facility, it is necessary to integrate, modify and/or update the contents of this manual, the Manufacturer shall provide the updated and revised chapters.

It is the responsibility of the user, following the instructions accompanying the updated documentation, to replace all copies held with the updated ones.

1.1.3 Confidentiality

The technical information (texts, drawings and illustrations) contained in this manual is the property of **THERMICS** and must be treated as confidential. It is strictly forbidden to disclose, reproduce or translate, even partially, this document without the written permission of **THERMICS**.

1.1.4 Recipients

This manual is intended for personnel who carry out the following operations on the machine:

- transport and handling;
- installation;
- use;
- adjustments;
- cleaning;
- maintenance and repair;
- demolition and disposal.



WARNING!

Make sure that operators do not intervene outside their specific areas of competence and responsibility.



IMPORTANT

This manual shall not in any way replace the specific technical training that operators must have previously received on similar machines or that they may attend on this machine under the guidance of qualified personnel.

1.2 Symbols

For the safety of persons and property, a special symbol has been used in this documentation to allow readers to focus on hazardous conditions, warnings or relevant information:



DANGER!

PAY UTMOST ATTENTION TO THE TEXT BLOCKS MARKED WITH THIS SYMBOL.

Danger with risk of injury or death.

Accident prevention regulations for the operator.



WARNING!

Possibility of causing damage to the machine and/or its components.

Pay attention.



IMPORTANT

Warning or note about key functions or useful information about the current operation.

1.2.1 Illustrations

The illustrations in this publication are current as of the date of issue.

In light of continuous technical or commercial updates, components may be mounted on the machine described in this manual, whose external shape may be different from that illustrated. Nevertheless, this does not affect such components' functionality and possibility of adjustment.

In case of doubt, contact the manufacturer directly for any further information.



1.3 General warnings

1.3.1 Allowed use

- Please read this booklet carefully.
- The documentation supplied with the unit must be handed over to the owner who must keep it carefully for future maintenance or servicing.
- The company shall not be liable for any damage to persons, animals or property arising from installation, adjustment and maintenance mistakes, improper use or a partial or superficial reading of the information provided herein; moreover, in view of the constant improvement of the products, the company reserves the right to modify the specified data at any time and without notice and declines all responsibility for any inaccuracies in this booklet, if due to printing or transcription errors.
- The machines are designed for heating and/or cooling water. A different use, not expressly authorised by the manufacturer, is to be considered improper and therefore not allowed.
- The location, hydraulic, cooling and electrical systems must be determined by the system designer considering both the merely technical requirements and any local legislation in force and specific authorisations.
- All works must be carried out by qualified, experienced personnel aware of the relevant regulations in force in the various countries.
- Upon delivery of the goods by the carrier, check the integrity of both the packaging and the units. If there is any damage or missing components, indicate it on the delivery note and forward a formal complaint to the company by fax or registered mail within 8 days from the date of good reception.
- The warranty does not apply if:
 - the personnel authorised by the company does not attend the machine start-up;
 - the above indications are not respected.

1.3.2 Remarks

- Pay particular attention to the use instructions preceded by the words "danger", "warning" or "important" because failure to respect them may lead to damage to the machine and/or people and property.
- The manufacturer declines all responsibility for any damage due to improper use of the machine, partial or superficial reading of the information provided herein.
- The machine must be installed in such a way that maintenance and/or repair operations are possible.
- The machine warranty does not cover the costs for ladders, scaffolding or other lifting systems that may be necessary to carry out works under warranty.
- The manufacturer does not provide drawings or specifications of connection systems.
- Any deviation from the prescriptions contained in this manual must be validated in writing by the manufacturer's technical support.
- For any faults not mentioned in this manual, please contact the Customer Service immediately.

1.3.3 User information

- Keep this manual and the wiring diagram in a place accessible to the operator.
- Note down the unit's identification data so as to provide it to the service centre in the event of a service request (see section "Machine identification").
- It is recommended to keep track of the works carried out on the unit to make the troubleshooting activity easier.
- In case of failure or malfunction:
 - check the type of alarm to report it to the service centre;
 - switch off the unit immediately without resetting the alarm;
 - contact an authorised service centre;
 - require the use of original spare parts.
- Ask the installer to be trained on:
 - power on/off;
 - shutdown for long periods;
 - maintenance;
 - what to do/not to do in case of failure.



2 Safety regulations



DANGER!

The machine has been designed and built according to appropriate safety standards. Before using the machine, carefully follow all the precautions and instructions provided in the manual to avoid accidents.

2.1 General safety rules

The use of products that use electricity and water involves compliance with certain basic safety rules such as the ones provided below:

- Children and unattended disabled persons are not allowed to use the machine.
- Do not touch the machine if you are barefoot and have wet or damp body parts.
- Any cleaning operation is prohibited without first disconnecting the power supply by turning the main switch of the system to "off".
- It is forbidden to modify the safety or adjustment devices without the authorisation and instructions of the machine manufacturer.
- It is forbidden to pull, disconnect or twist the electrical cables coming out of the machine, even if it is disconnected from the power supply.
- It is forbidden to open the access doors to the internal parts of the machine, if the system has not been switched off by means of the main switch.
- It is forbidden to climb on the machine with your feet, sit and/or lean against any type of object.
- It is forbidden to spray or throw water directly on the machine.
- The packaging material (cardboard, staples, plastic bags, etc.) may not be dispersed or left within the reach of children, as it may be a potential source of danger.
- Observe the safety distances between the machine and other equipment or structures to ensure sufficient access space to the unit for maintenance and/or servicing as indicated in this manual.
- Power supply of the machine: the machine must be powered by means of electrical cables with a section suitable for the power of the unit and the power supply voltage values must correspond to those indicated for the respective machines; all the machines must be connected to earth as per the regulations in force in the various countries.
- The hydraulic connection must be carried out according to the instructions in order to ensure the correct operation of the machine.
- During the cold season, if the machine is not working, empty all the hydraulic circuits of the machine to prevent them from freezing.
- Handle the machine with the utmost care and avoid damaging it.
- Glycol solution: the heat exchangers' antifreeze alarms are set based on the mixture declared at the start-up. Breakages due to inadequate mixing or mixture not maintained over time are not covered by the manufacturer's warranty.
- Installation room: some machine components generate heat during operation.
- The installation room must ensure adequate ventilation and proper dissipation of the heat produced.



2.2 Security pictograms

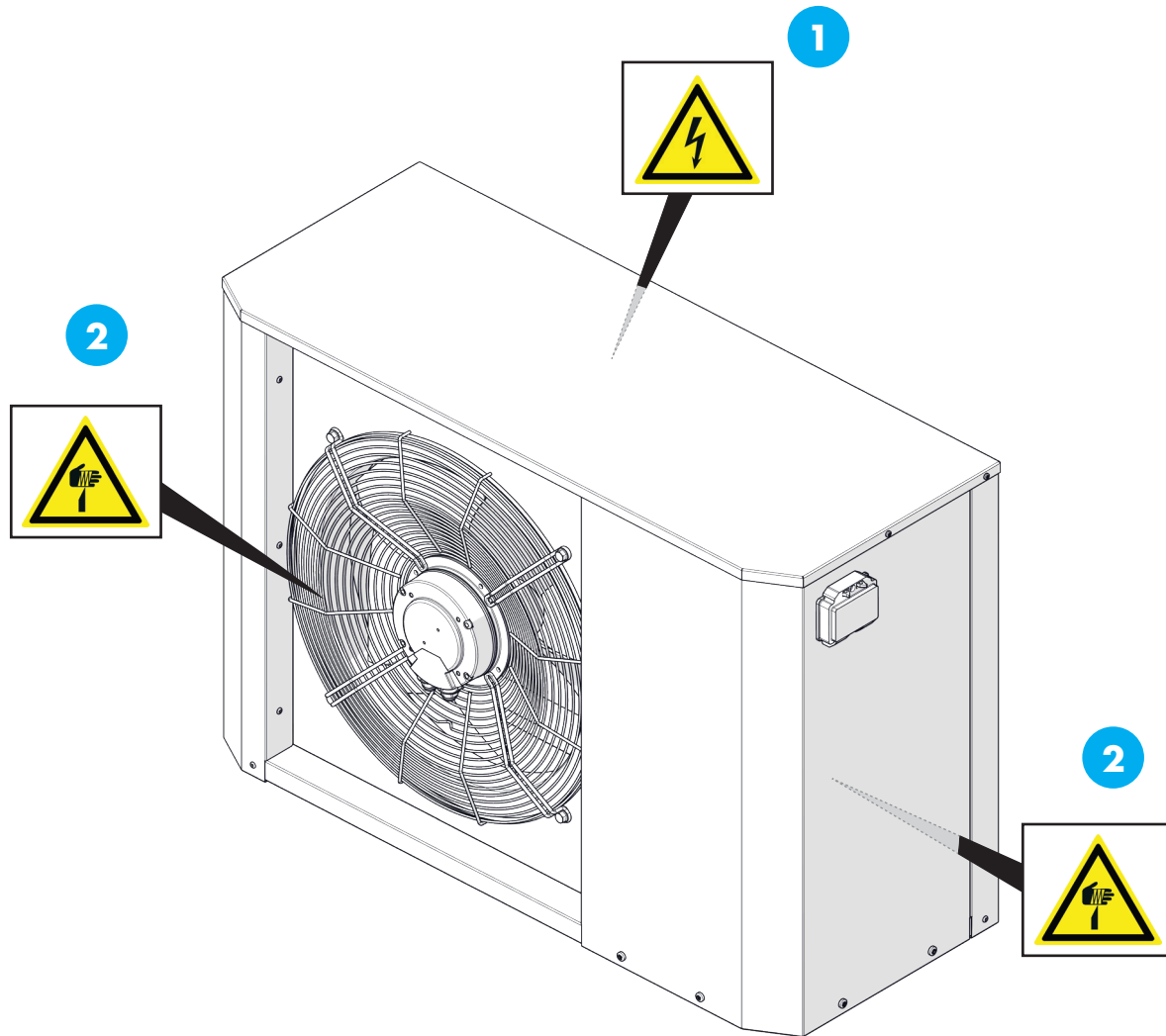

- 1 Electricity hazard
- 2 Sharp object hazard

3 Reception and handling

3.1 Handling with packaging

The machine is supplied on wooden pallets protected by cardboard packaging.



WARNING!

Use spacers to avoid damaging the machine .



WARNING!

The machine is supplied with the vibration dampers already installed; handle the units carefully to avoid damaging them.



WARNING!

During handling, it is forbidden to exceed the maximum permitted inclination of 30°.

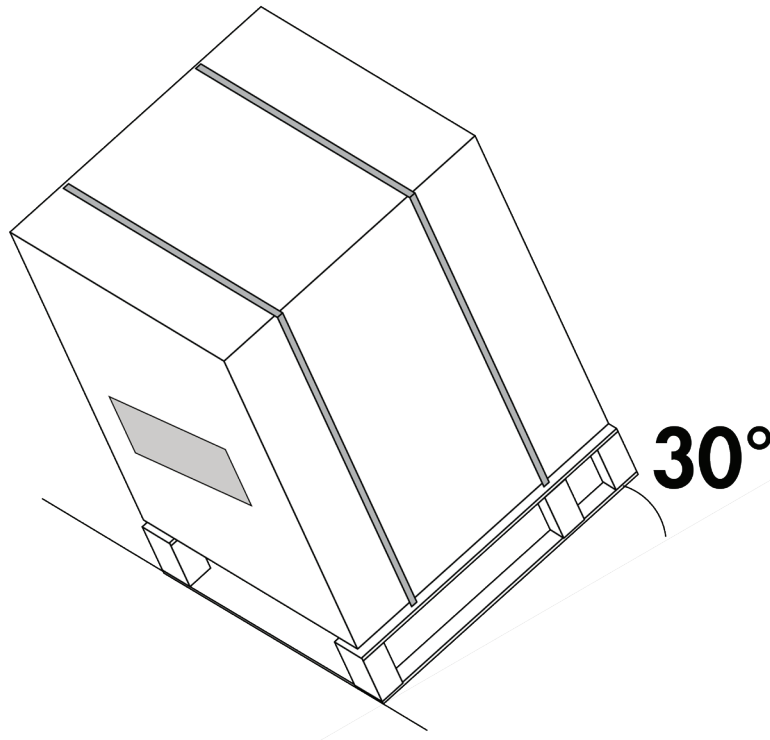

Lifting with forks

- Insert the forks from the side so as not to damage the panels.

Lifting with crane

- Position the lifting belts as shown in the figure.

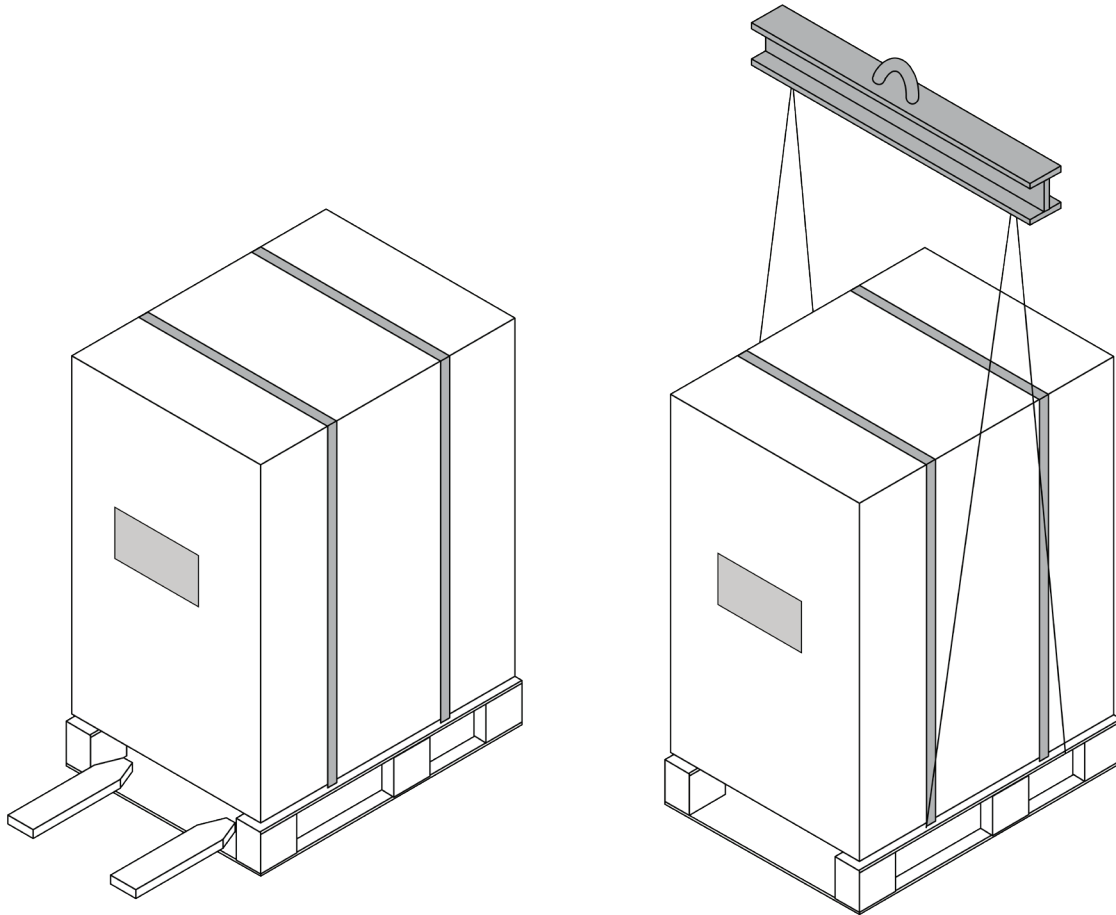

3.2 *Verification of packaging*

Before accepting the received goods, please check that:

- the machine has not been damaged during transportation;
- the material delivered corresponds to that indicated on the transport document by comparing the data with the packing plate.

In case of damage or faults:

- immediately note down the damage on the transport document and write: "Delivery accepted with reserve due to noticeable missing parts/transport damage";
- complain by sending an PEC e-mail and registered letter with advice of receipt to the carrier and the supplier.



3.3 Packaging content

THE STANDARD SUPPLY INCLUDES:

- 1 Heat pump
- 2 Technical documentation



WARNING!

Keep the manual in a dry place, to avoid deterioration, for at least 10 years for future reference.

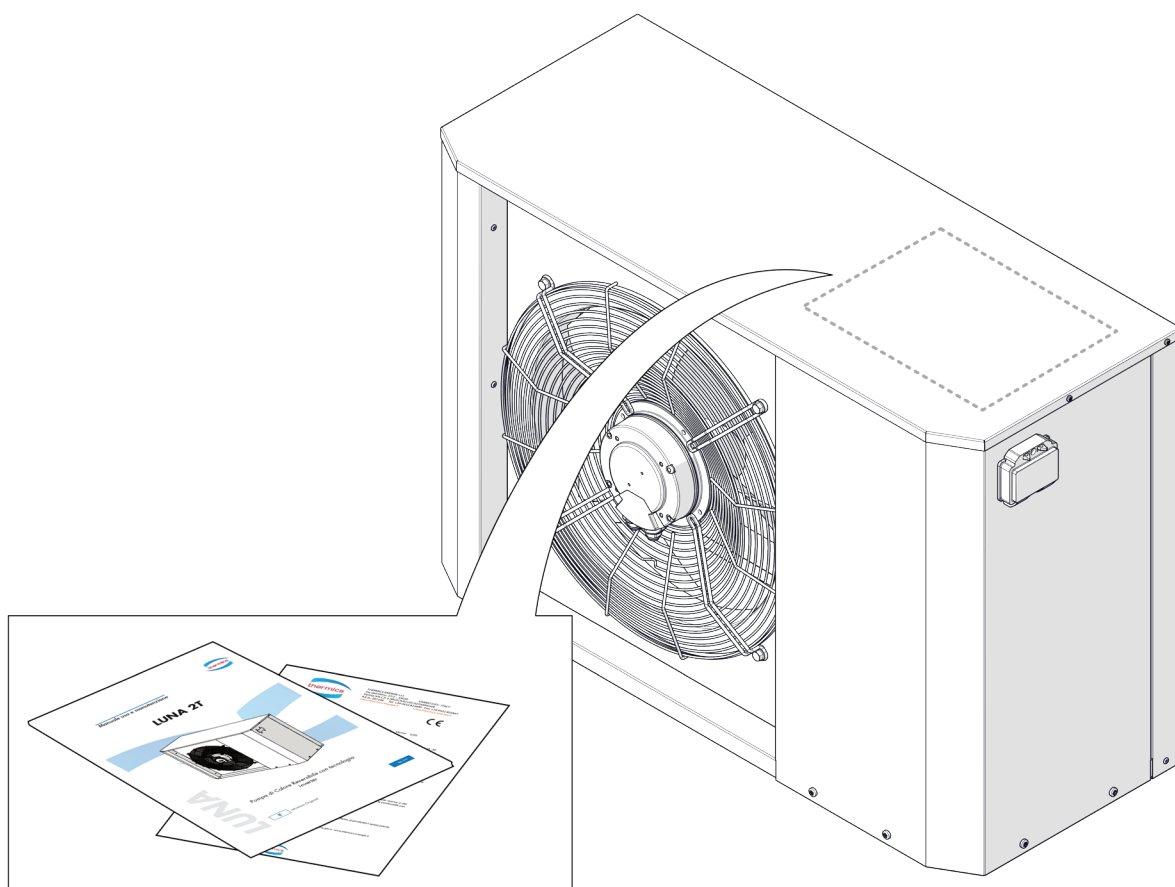

3.4 Removing the packaging

- Cut the fixing straps.
- Remove the top part by lifting it upwards.
- Remove any protective inserts.
- Remove the transparent film that wraps the machine.

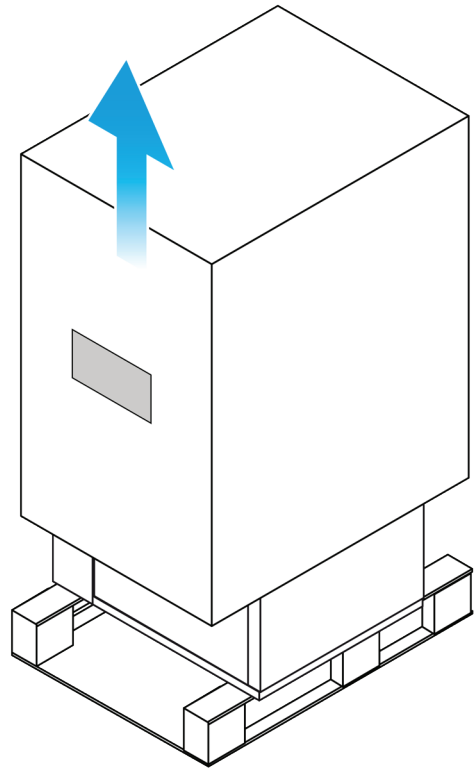
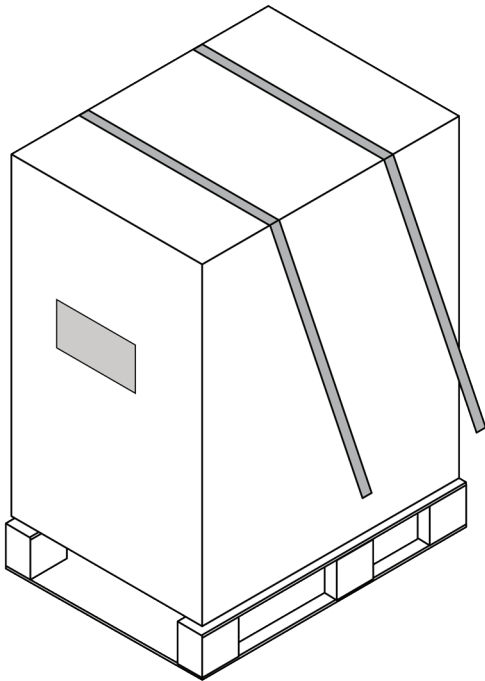

3.5 Handling without packaging

Use handling equipment suitable for the machine weight.



DANGER!

The unit is supplied with the vibration dampers already installed; handle the unit carefully to avoid damaging them.



DANGER!

Use spacers to prevent damage to the unit.

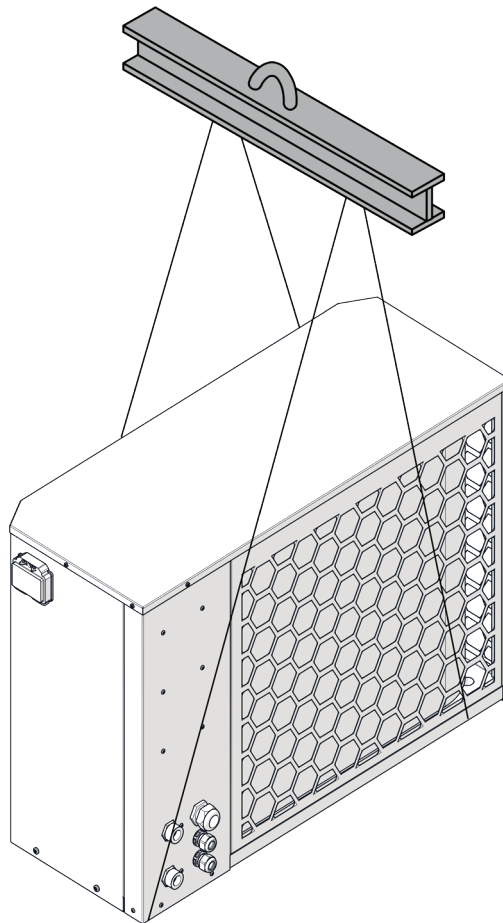

4 Mounting

4.1 Recommended equipment

To install the machine it is advisable to use the following equipment:

- set of cross-head and slotted screwdrivers;
- cutting nippers;
- scissors;
- set of open end wrenches and pipe wrenches;
- ladder;
- hydraulic material for sealing the threads;
- electrical equipment for connections;
- cut-resistant protective gloves.



4.2 System inspection



DANGER!

Current regulations require the heating system to be inspected before commissioning. The inspection must be carried out by a qualified technician.

Fill in the following check list on the installation data:

SYSTEM

Description	Notes	Signature	Date
<input type="checkbox"/> Washed system			
<input type="checkbox"/> Vented system			
<input type="checkbox"/> Impurity filter			
<input type="checkbox"/> Cut-off and drain valve			
<input type="checkbox"/> Set filling flow rate			

ELECTRICITY

Description	Notes	Signature	Date
<input type="checkbox"/> Home fuses			
<input type="checkbox"/> Safety switch			
<input type="checkbox"/> Differential switch			
<input type="checkbox"/> Communication cable connected (if any)			
<input type="checkbox"/> Connections			
<input type="checkbox"/> Main voltage			
<input type="checkbox"/> Phase voltage			

MISCELLANEOUS

Description	Notes	Signature	Date
<input type="checkbox"/> Condensate water pipe			
<input type="checkbox"/> Condensate water pipe insulation, thickness			
<input type="checkbox"/> Cooling pipes according to the procedure indicated (if present).			

4.3 Verification of functional spaces

The installation of the machine must allow specialised and authorised personnel to easily perform maintenance activities while respecting both the safety distances between the units and the other equipment and the technical spaces indicated in the table.

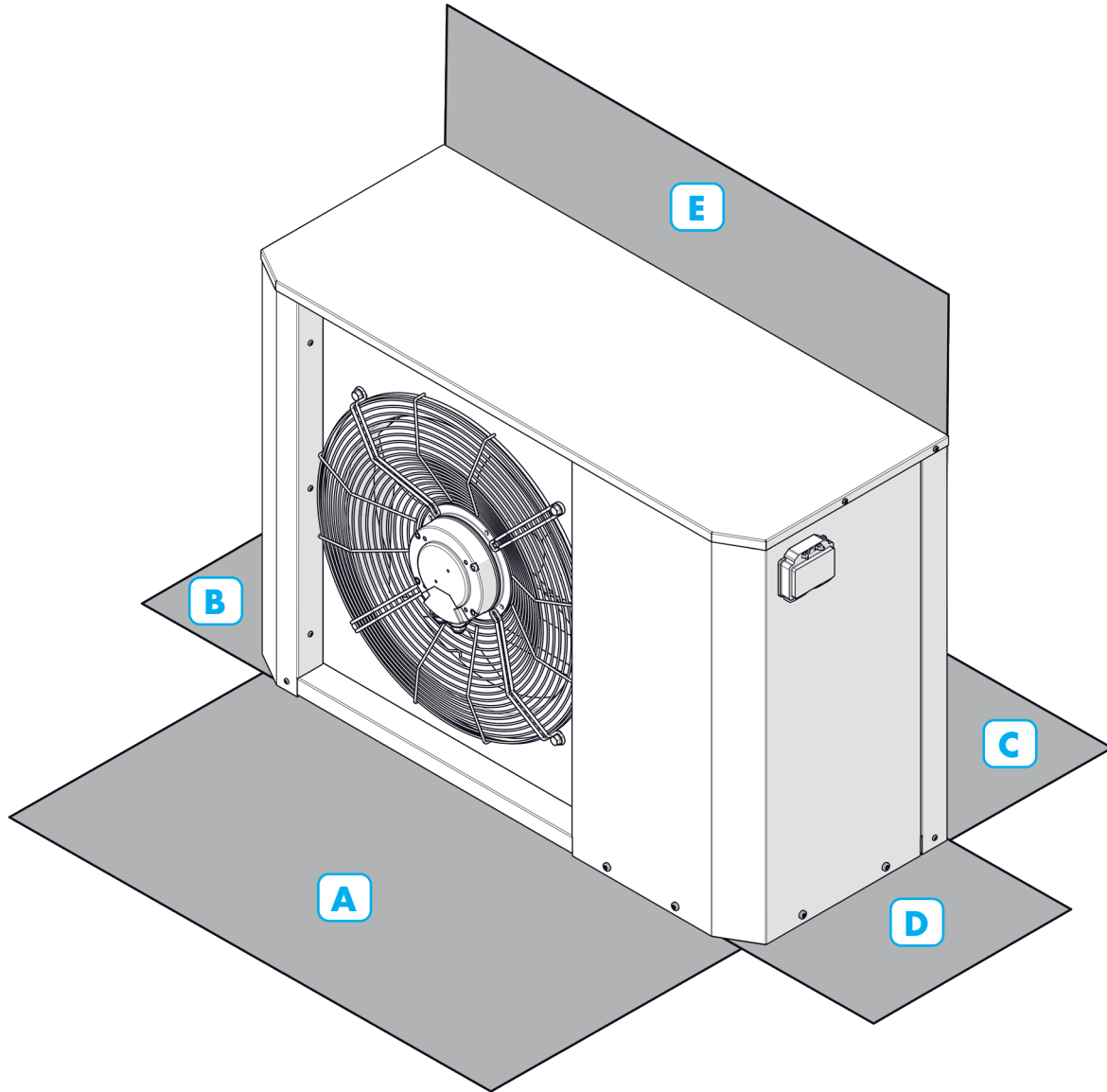

	A	B	C	D	E
LUNA 2T 6 kW 2T MB	2000	500	300	800	300
LUNA 2T 8 kW 2T MB	2000	500	300	800	300
LUNA 2T 10 kW 2T MB	2000	500	300	800	300
LUNA 2T 12 kW 2T MB	2000	500	500	800	300
LUNA 2T 14 kW 2T MB	2000	500	500	800	300
LUNA 2T 16 kW 2T MB	2000	500	500	800	300

4.4 Unit positioning

The vibration dampers (1) are supplied fully screwed in.

- To adjust the height of the vibration dampers (1) turn counterclockwise (A) to raise the angle.



DANGER!

Check that the table supports the machine weight.

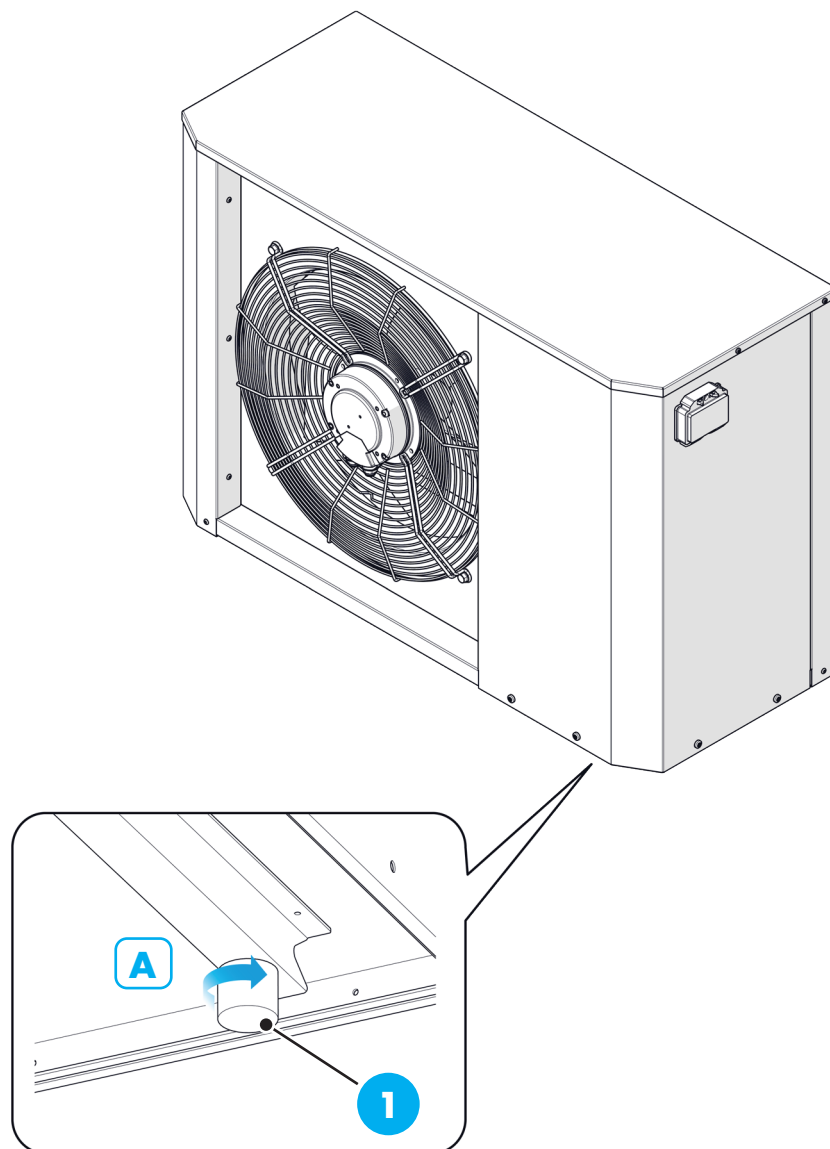

4.5 Noise control

During installation, take into account the effect that the position of the machine will have on the noise emitted. Position the machine as far away from walls as possible. The noise level increases according to the place of installation as illustrated below:

- A.** Module positioned against a wall: +3 dB(A)
- B.** Module positioned in a corner: +6 dB(A)
- C.** Module positioned in a confined indoor space: +9 dB(A)



IMPORTANT

Avoid placing the module near the bedroom area and a terrace.
Do not install the module in front of a wall.

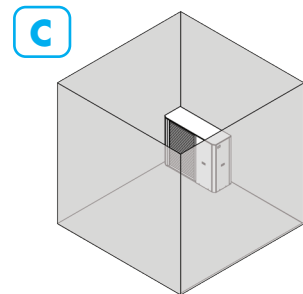
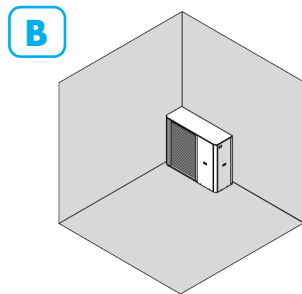
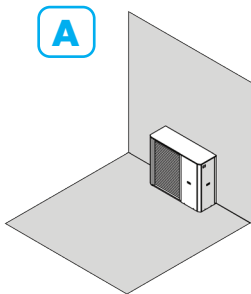

4.6 Where not to install

It is strictly prohibited to install the equipment with the:

- A.** Ventilation directed towards neighbouring properties
- B.** Module positioned at the edge of the property
- C.** Module positioned under a window
- D.** Module placed near the bedroom area
- E.** Module installed in front of a wall

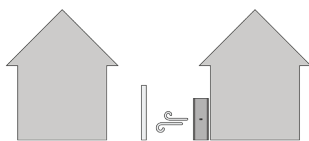

A

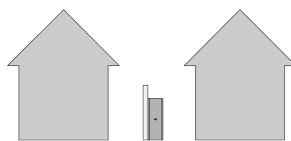

B



C



D

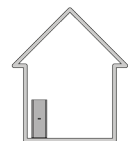

E



4.7 Recommendations and suggestions

In order to limit acoustic disturbances and vibrations, we suggest that you do the following:

- Install the module outdoors on a metal frame or on an inertia base. The weight of this base must be at least twice the weight of the module.
- Use modified bushes or sleeves for passing the refrigerant connections through walls.
- Use flexible and anti-vibration materials for fixing.
- Use vibration-damping devices on coolant connections, such as rings, plates, or elbow joints.
- It is also recommended to use sound absorbing devices such as:
 - wall absorbers to install on the wall behind the module
 - acoustic screen: the surface area of the screen must be larger than the size of the external module and must be positioned as close as possible to it, while still allowing free air circulation. The screen must be made of suitable materials, such as soundproofing bricks, concrete blocks covered with sound-absorbing materials or natural screens such as earth.

4.8 Access to internal parts



DANGER!

Before removing the side panels, make the hydraulic connections.



DANGER!

When removing the Control Panel dashboard, pay attention to the connection cable.

To access the internal parts, remove the panel of the concerned area (A-B):

- loosen the screws (1) at the bottom of the panel (2);

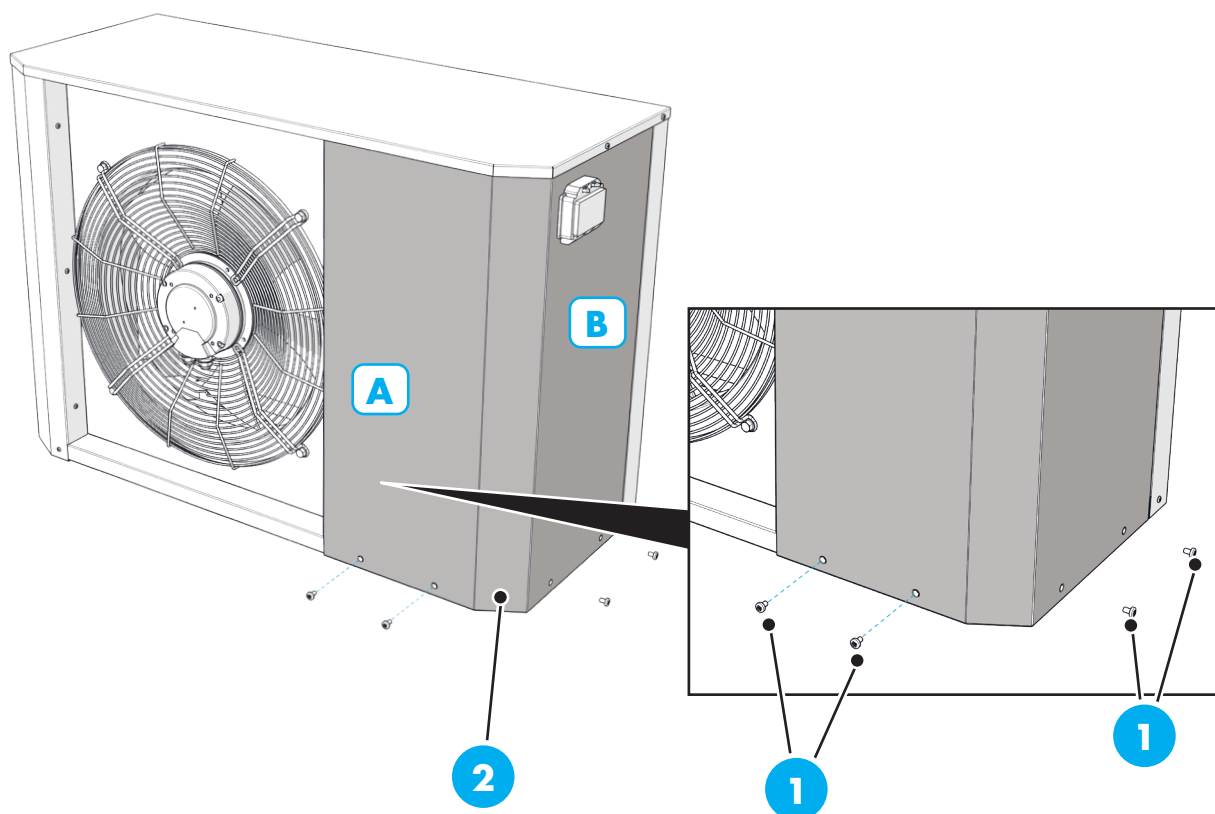

- if necessary, remove the upper panel (3) by loosening its retaining screws;

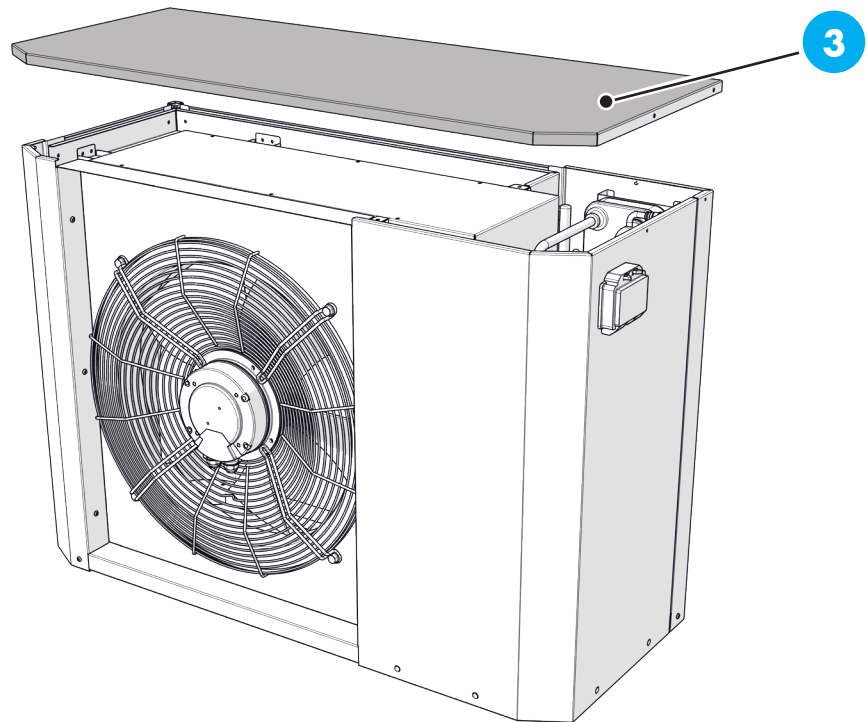

- disengage the panel (2) by sliding it outwards;

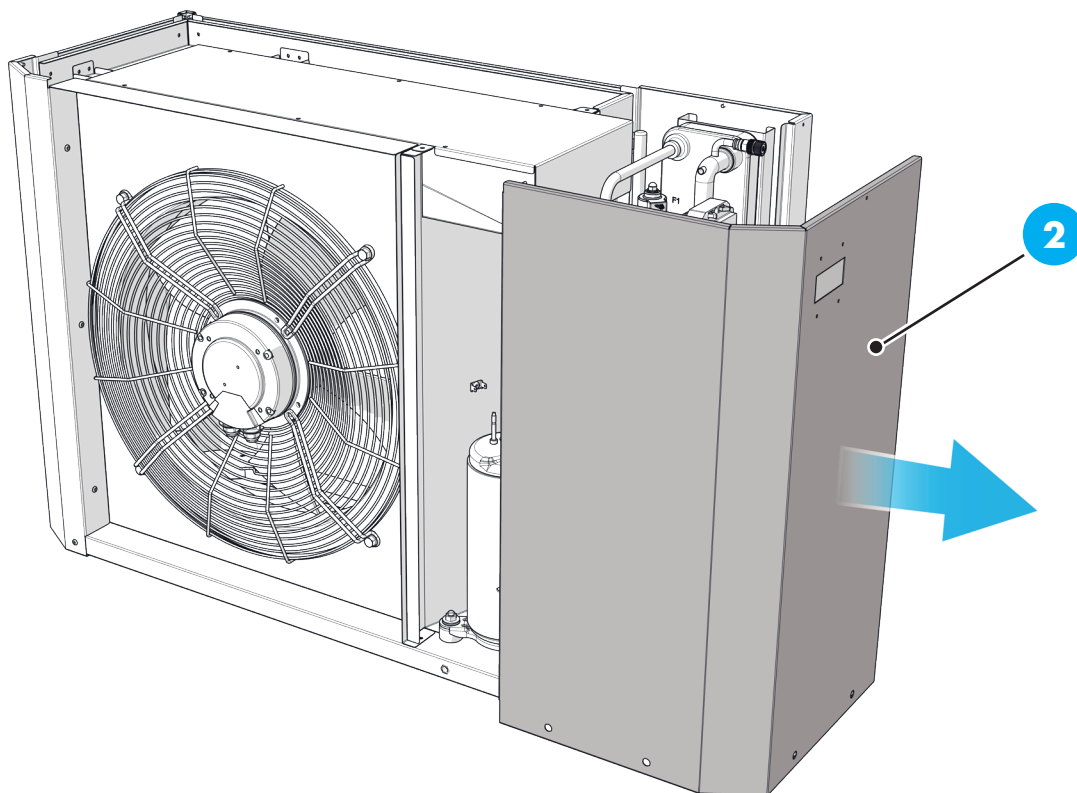

- remove the panel (4) of the electrical panel (5) by loosening the screws (6).

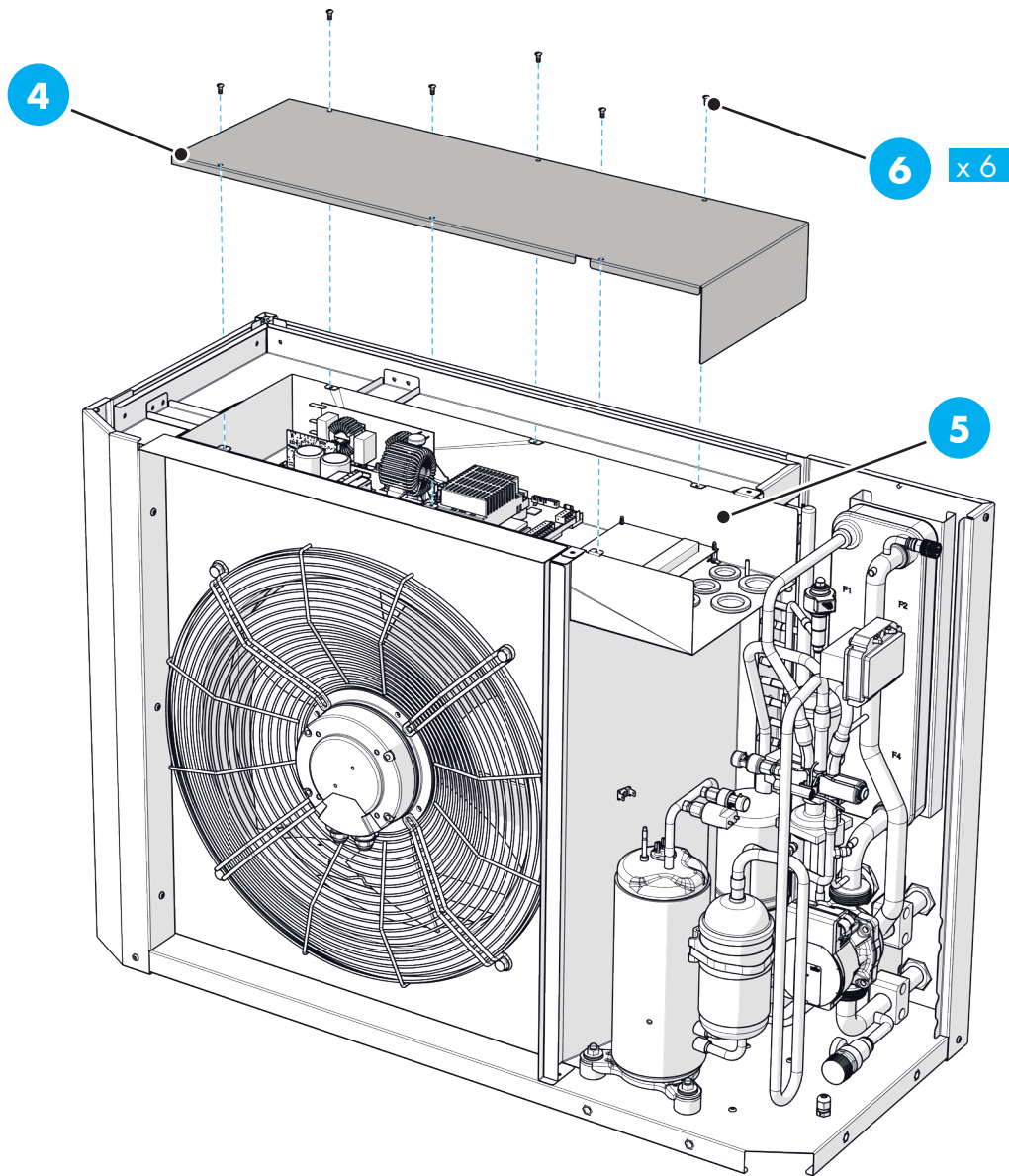

4.9 Hydraulic diagrams

System side hydraulic connections

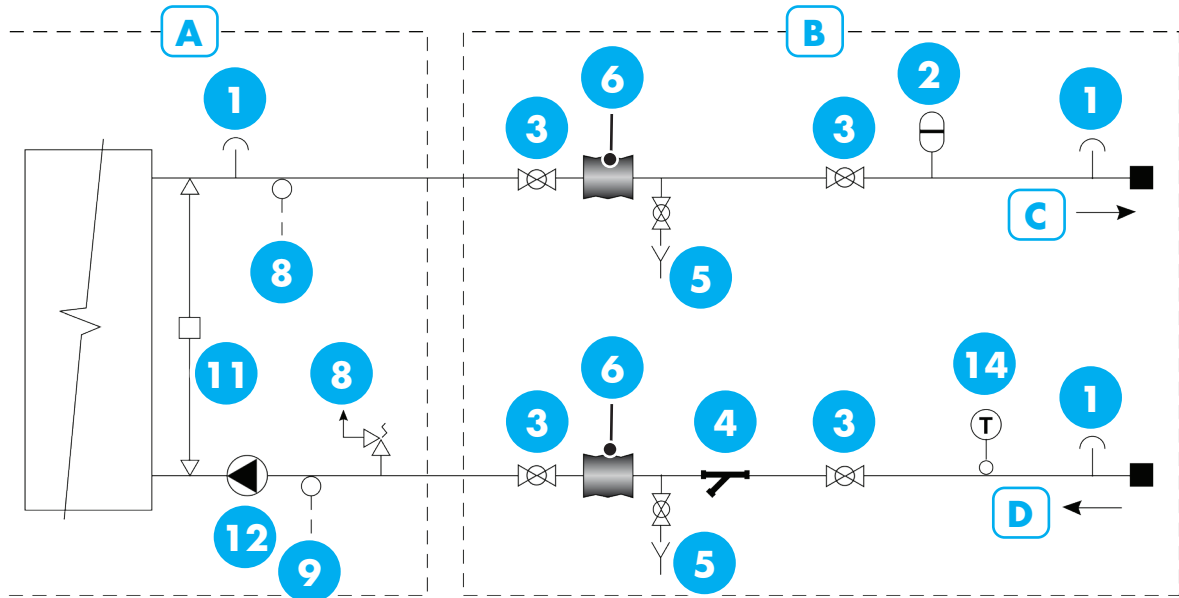

KEY TO HYDRAULIC CONNECTIONS

A Connections by the manufacturer	C System flow
B Connections by the installer	D System return line

KEY TO HYDRAULIC CONNECTIONS

1 Vent valve	8 Safety valve
2 Expansion vessel	9 Temperature probe
3 Shut-off cock	10 Discharge
4 Mesh filter	11 Differential pressure switch
5 Drain cock	12 Circulation pump
6 Vibration damper	13 Pressure gauge
7 Filling cock	14 Temperature gauge

4.10 Machine connections

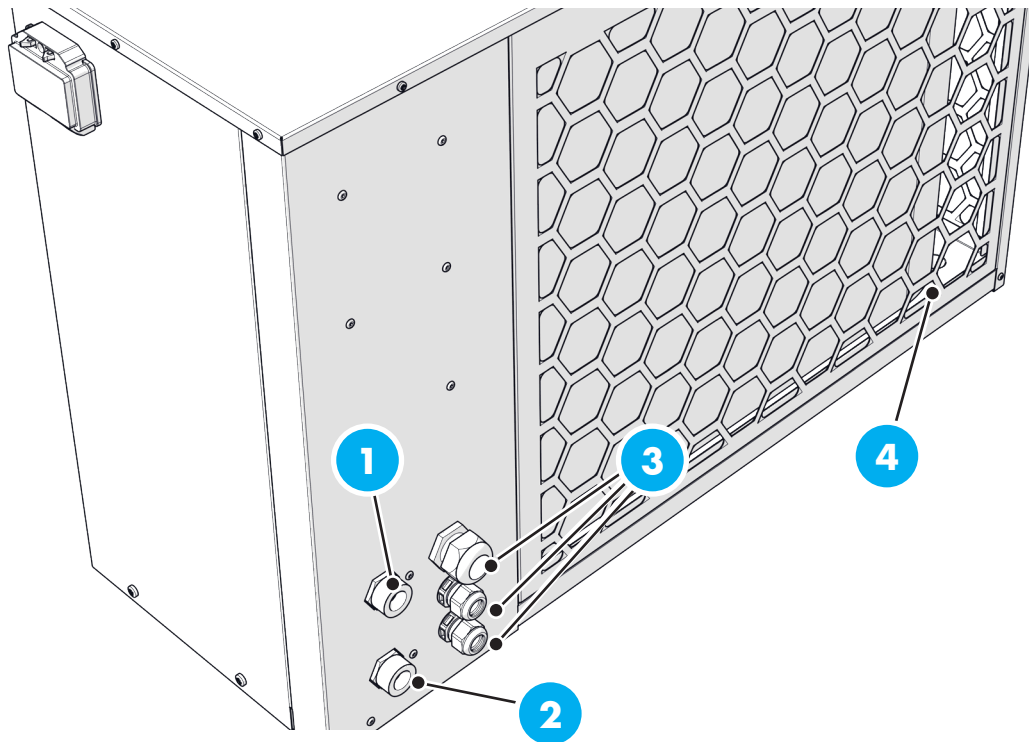

KEY

- | | |
|---|------------------|
| 1 | System outlet |
| 2 | System inlet |
| 3 | Cable glands |
| 4 | Condensate drain |

4.10.1 Propylene glycol solution

PROPYLENE GLYCOL SOLUTION

Data	0	-3	-7	-12	-18	-20
------	---	----	----	-----	-----	-----

PERCENTAGE OF PROPYLENE GLYCOL BY WEIGHT

	0	10%	20%	30%	36%	40%
cPf	1	0.99	0.985	0.98	0.97	0.965
cQ	1	1.02	1.04	1.075	1.11	1.14
cdp	1	1.07	1.11	1.18	1.22	1.24

- **cPf**: Cooling capacity correction factor
- **cQ**: Flow rate correction factor
- **cdp**: Pressure drop correction factor

4.10.2 Example of connection diagram

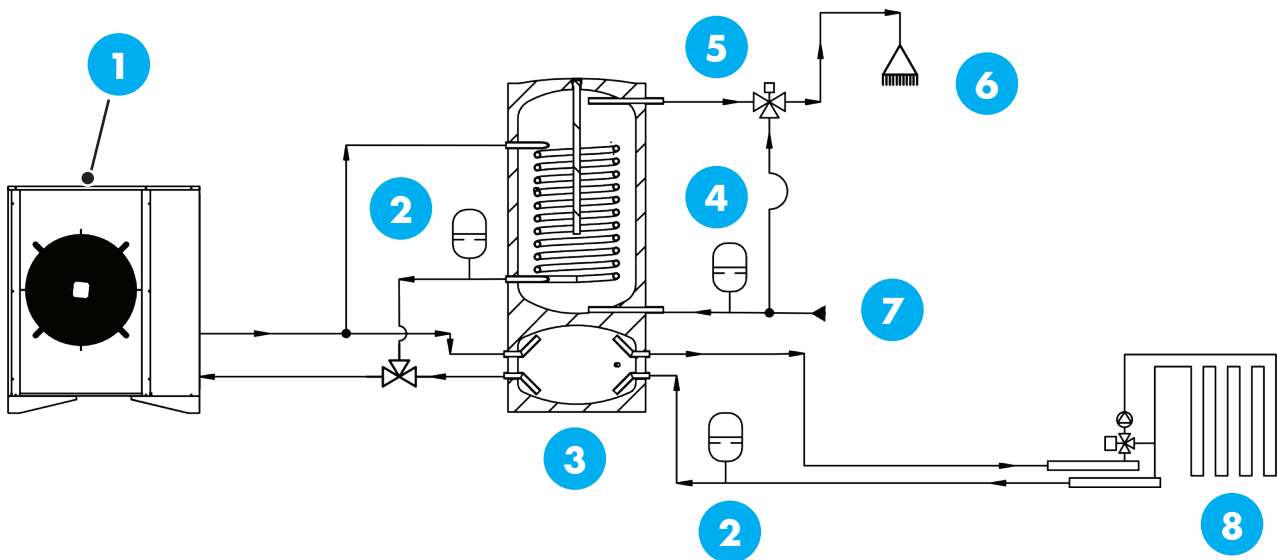

KEY

1 LUNA 2T 2 pipes	5 Mixer
2 V.E. Heat.	6 Utilities
3 Double accumulation DHW + Technical	7 Cold water inlet
4 V.E. DHW	8 System

4.11 Hydraulic connection



DANGER!

The pipes must be installed in accordance with the prevailing standards and directives.

- The machine can operate at a maximum return temperature of 55°C and at a heat pump outlet temperature of 65°C on the system side.
- The machine is not equipped with hydraulic side cut-off valves. They must be installed to facilitate any future maintenance work.
- The return flow temperature is limited by the return flow sensor.

4.11.1 Water volumes

The water volume required for optimal machine operation (avoiding short operating times and enabling defrosting) varies depending on the machine model.

A minimum available water volume of 8 litres per size number is recommended conditions.

For example for LUNA 2T

$$8 \text{ litres} \times 10 = 80 \text{ litres}$$



WARNING!

Pipes must be discharged before the heat pump is connected so that any type of contaminant does not damage the components.

4.11.2 Heating fluid circuit

- Vent the heat pump through the manual valves located on each water circuit. If there is an automatic breather valve, make sure it is operating correctly.
- Install the impurity filter.
- All external pipes shall be thermally insulated with pipe insulation material at least 19 mm thick.
- Install the cut-off and drain valves so that the machine can be emptied in the event of a prolonged power supply interruption.
- The connecting pipes must be provided with shut-off cocks and anti-vibration joints, which have the function of damping vibrations and prevent them from propagating to the system.
- An appropriately sized expansion tank and an additional safety valve (3 bar) must be installed on each water circuit.

4.11.3 Plant pump

The system pump is powered and controlled by the internal control panel.

The machine features an integrated anti-freezing function and therefore must not be switched off in conditions with a risk of freezing.

At temperatures below +2°C the filling pump works periodically to prevent the water from freezing in the primary circuit.

The function also protects against excessive temperatures within the flow circuit.



4.11.4 Water quality - recommendations

In order to maintain the functionality and durability of the internal components as well as the performance of the unit, please follow the recommendations below.

Firstly, you should try to prevent corrosion, which is a complex process that depends on the interaction of the different materials with the various chemicals dissolved in the water.

The standard UNI 8065:1989 specifies the chemical and chemical-physical parameters of water in heating systems for domestic use:

For hot water heating systems, the standards specifies the following characteristics for the water in the circuit.

CIRCUIT WATER CHARACTERISTICS

Appearance	Preferably clear
pH	Higher than 7 (for radiators with aluminium or light alloy elements the pH should also be less than 8)
Conditioners	Present within the concentrations specified by the manufacturer
Iron (as Fe)	<0.5 mg/kg (higher values of iron are due to corrosion that should be eliminated)
Copper (as Cu)	<0.1 mg/kg (higher values of copper are due to corrosion that should be eliminated)

The quality of the water should be periodically checked using the Ryznar (RSI) and Langelier (LSI) indices, which should be within the limits and values indicated below:

- Water temperature (°C)
- Fixed residue (mg/l)
- Ca²⁺ as CaCO₃ (mg/l)
- Alkalinity as CaCO₃ (mg/l)

<i>ELEMENT/COMPOUND/PROPERTY</i>	<i>VALUE/UNIT</i>
pH	7.5 – 9.0
Conductivity	< 500 µS/cm
Hardness	4.5 – 8.5 dH°
Free chlorine	< 1.0 ppm
Ammonia (NH₃)	< 0.5 ppm
Sulphate (SO₄²⁻)	< 100 ppm
Hydrogen carbonate (HCO₃⁻)	60 – 200 ppm
(HCO₃⁻) / (SO₄²⁻)	> 1.5
(Ca + Mg) / (HCO₃⁻)	> 0.5
Chloride (Cl⁻)	In accordance with the following graph
Oxygen	< 0.02 mg/l

Performance limits (Crevice corrosion) of Alloy 316 in water containing chlorides

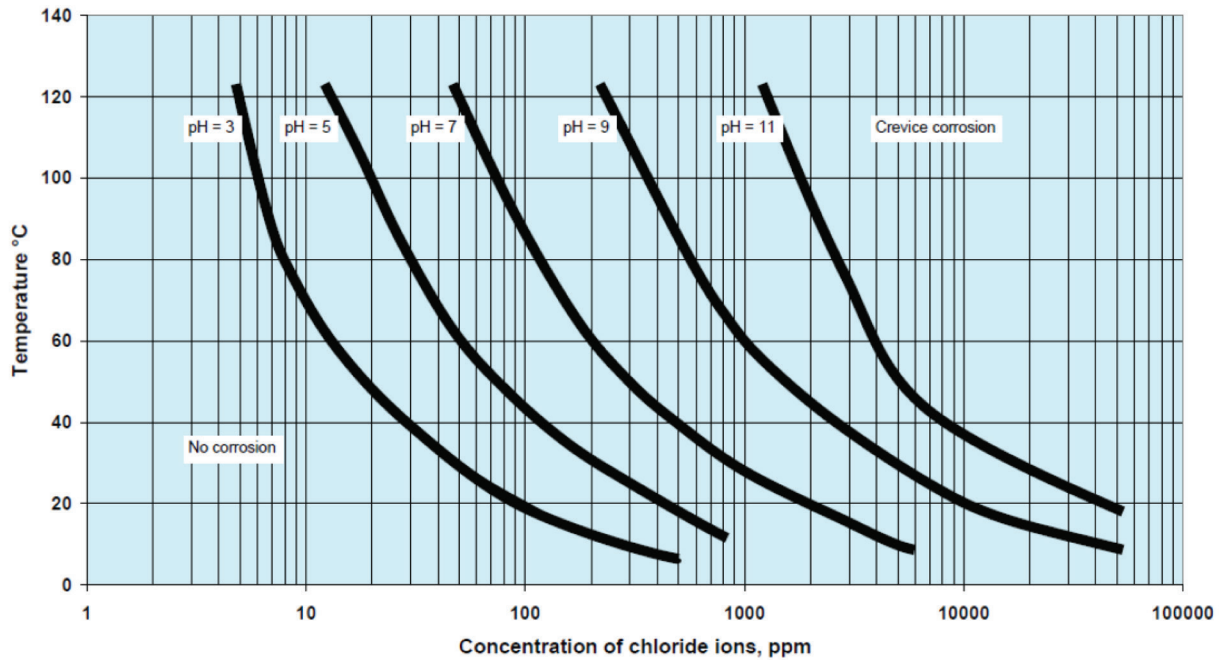

It is also recommended that you follow the guidelines outlined in standard VDI 2035 "Guideline for the prevention of damage in water heating installations" designed to prevent the presence of oxygen in the water.

- Keeping the pH within the limits indicated above prevents the formation of magnetite. It is recommended to use chemical inhibitors suitable for this purpose.
- Magnetite forms because of corrosion that forms due to the action of oxygen in a closed circuit. If it is present in high quantities, it is probably because there is a leak in the circuit that allows it to get in.

4.12 Connecting the condensate drain

The condensate water tank (1) collects and eliminates most of the condensate water produced by the heat pump (2).

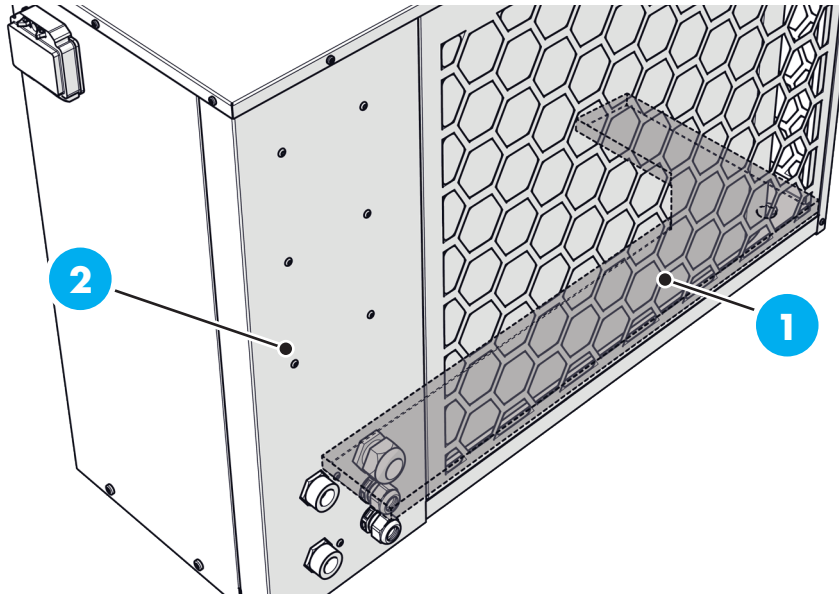

WARNING!



For the heat pump to function, the condensate water must be regularly removed and the condensate water drain must be correctly positioned so as not to damage the house. The condensate flow must be checked regularly, especially in the autumn. Perform cleaning when necessary.



IMPORTANT

The pipe with heating cable for draining the condensate tank is not included.

- Condensate water collected in the tank (up to 50 litres/24 hours) must be conveyed to an appropriate drain by means of a pipe; it is recommended to use the shortest possible external path.
- The pipe section of the pipe subject to frost must be heated by means of the heating cable.
- Direct the tube downwards.
- The condensate pipe outlet must be positioned at a depth or an internal point protected from frost (in accordance with local laws and regulations).
- Use a siphon for installations where air can circulate in the condensate water pipe.
- The insulation must adhere to the lower part of the condensate water tank.



4.12.1 Condensation water diversion

- If the house has a cellar, the stone box (3) must be positioned so that the condensate water does not affect the house. Alternatively, the stone box (3) can be placed directly under the heat pump (2).
- The outlet of the condensate water pipe (4) must be located at a depth protected from frost (A).

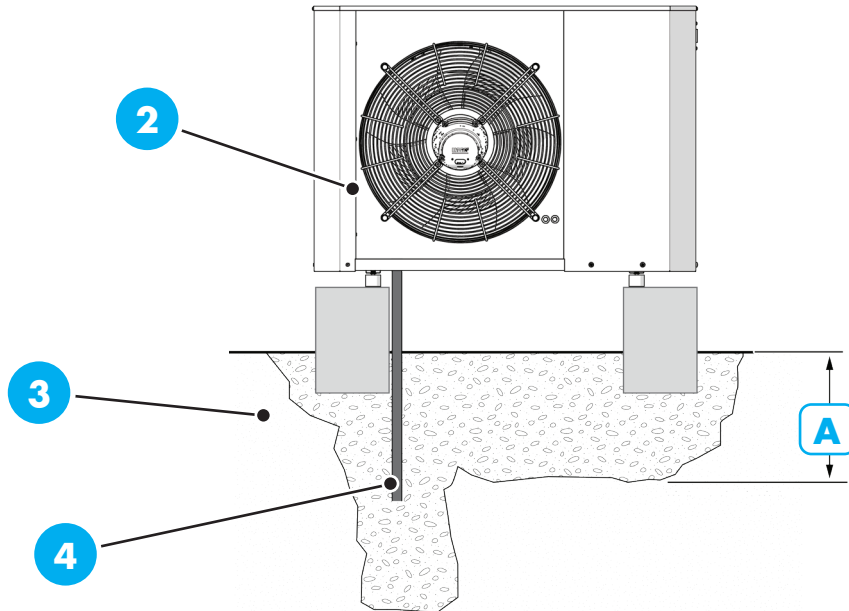

4.12.2 Internal drain

- The condensate water is directed to an internal drain (in accordance with local laws and regulations).
- The condensate water pipe (4) must be equipped with a siphon (5) to prevent air circulation inside the pipe.

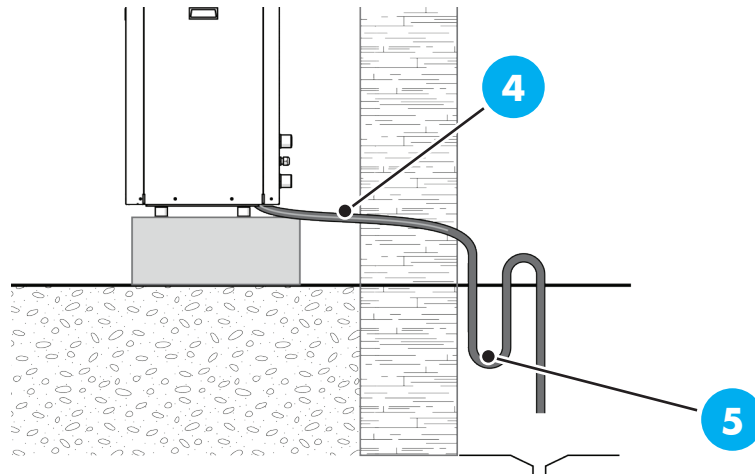

4.12.3 Drain into the gutter pipe

- The outlet of the condensate water pipe (4) must be located at a depth protected from frost.
- Direct the tube downwards.
- The condensate water pipe (4) must be equipped with a siphon (5) to prevent air circulation inside the pipe.

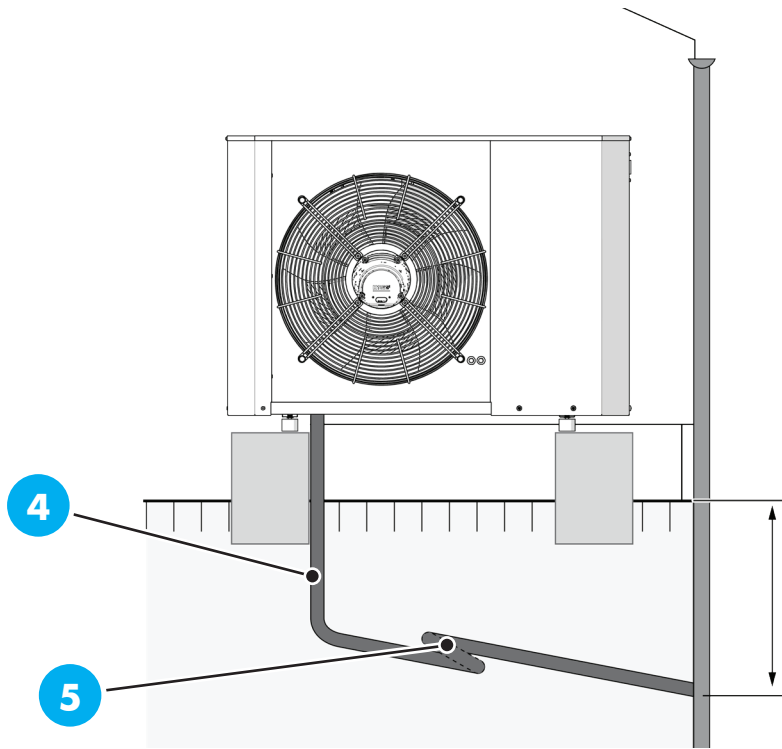

4.13 Power supply connection

- Connect the cable to the terminals inside the electrical panel by passing it through the appropriate cable glands located on the lower part of the panel.
- Refer to the attached wiring diagrams for connections.
- In order to correctly size the cross section of the machine power cables, please take into account the data in paragraph "1.1 Assorbimenti".



DANGER!

The heat pump must not be connected without the permission of the electricity supply company and must be connected under the supervision of a qualified electrician.



DANGER!

The unit does not include a circuit breaker on the input power supply.

The power cable of the heat pump must be connected to a thermal-magnetic circuit breaker with a break gap of at least 3 mm. If the building is equipped with an earthed residual-current circuit breaker, the heat pump must have a separate switch. The earthed residual-current circuit breaker must be a type B device that is sensitive to direct currents and have a rated trip current not exceeding 30 mA. If possible, it should also have the following characteristics:

1. Adjustable trip threshold
2. Adjustable trip delay
3. Be dedicated to the heat pump only.

The input power supply must be 400 V 3 N~ 50 Hz through a power distribution unit with thermal-magnetic protection.

For 230 V~ 50 Hz the input power supply must be 230 V~ 50 Hz through electrical panel with thermal-magnetic protection.



DANGER!

The electrical system and any maintenance work must be carried out under the supervision of a qualified electrician. Switch off the power supply via the circuit breaker before performing any maintenance work. The system and the electrical wiring must be carried out in accordance with the prevailing national regulations.



DANGER!

High-current and signal cables must be routed through separate cable glands.



DANGER!

Avoid direct contact with the copper pipes and the compressor.



**DANGER!**

After about 10 minutes of heat pump operation, make sure that the screws on the power supply terminal block are tightened.

**WARNING!**

Check the connections, the main voltage and the phase voltage before starting the machine to avoid damage to the electronics of the air/water heat pump.

4.13.1 Connections LUNA 2T 06 - LUNA 2T 08 - LUNA 2T 10

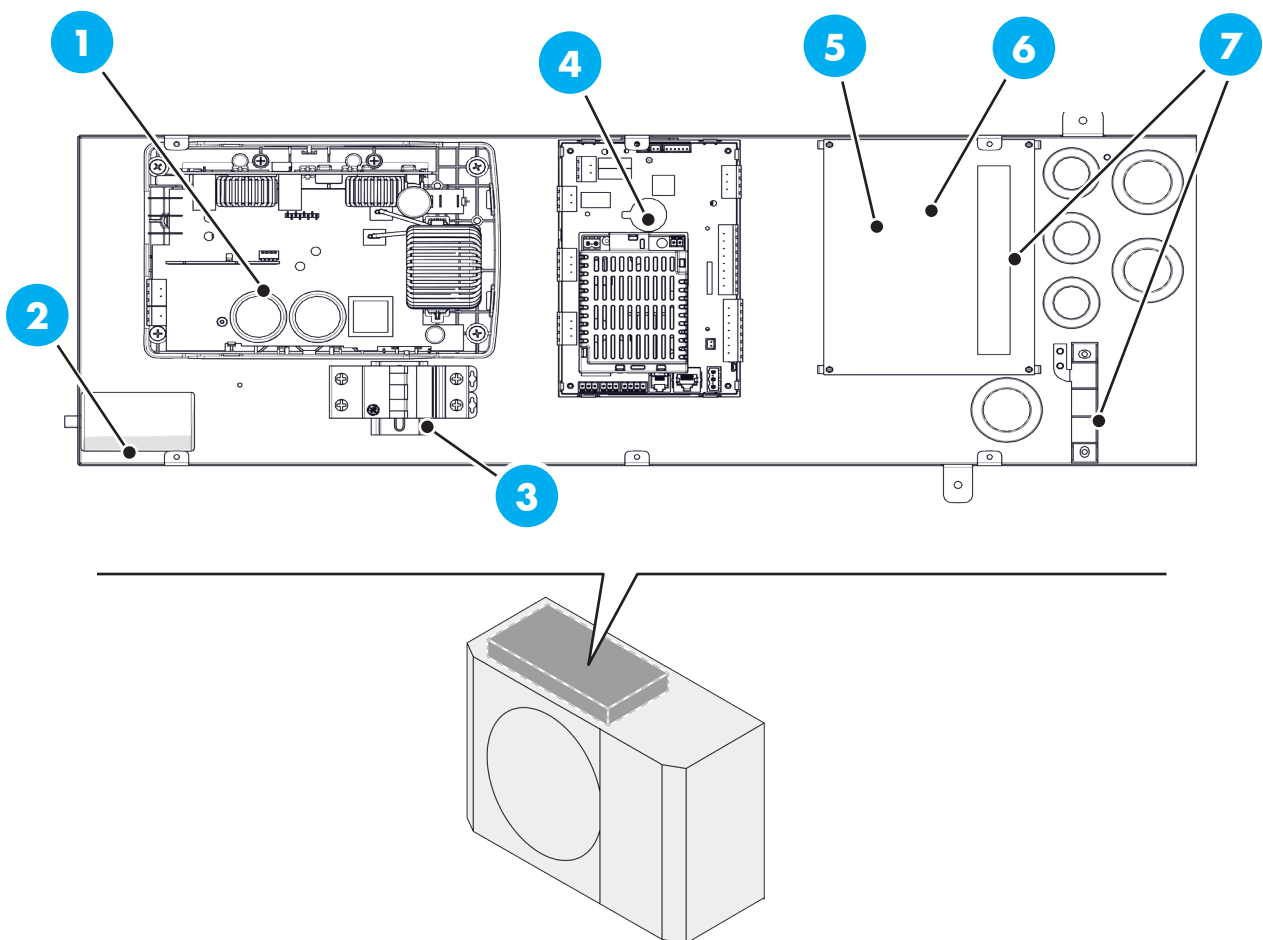

CONNECTIONS

1	A2 - Compressor inverter	6	Connector B
2	TC1	7	Connector C
3	QM1- Compressor thermal-magnetic circuit breaker	8	Connector D
4	A3	9	Fuse terminal blocks (FU1...FU6)
5	Connector A	10	User terminal blocks

FUSE PROTECTION TERMINAL BLOCK

9	FU1	Fan protection fuse
	FU2	Protection fuse for system circuit circulator
	FU3	Auxiliary circuit protection fuse 230 V
	FU4	Auxiliary circuit protection fuse 230 V
	FU5	Auxiliary circuit protection fuse 230 V
	FU6	Auxiliary circuit protection fuse 24 V

USER TERMINAL BLOCK

10	OP	
	L	Unit power connections
	N	
	1	NC: Alternative system water source enable
	2	NO: Alternative system water source enable
	3	C: Contact power supply
	4	
	5	Settable multifunction input.
	6	
	7	Domestic hot water storage probe
	8	
	9	Enable for alternative DHW source (230 V - 1 A max)
	10	
	11	3-Way valve enable (230 V - 1 A max)
	12	
13		
14	Unit display connection (A4)	
15		



4.13.2 LUNA 2T 12 - LUNA 2T 14 - LUNA 2T 16

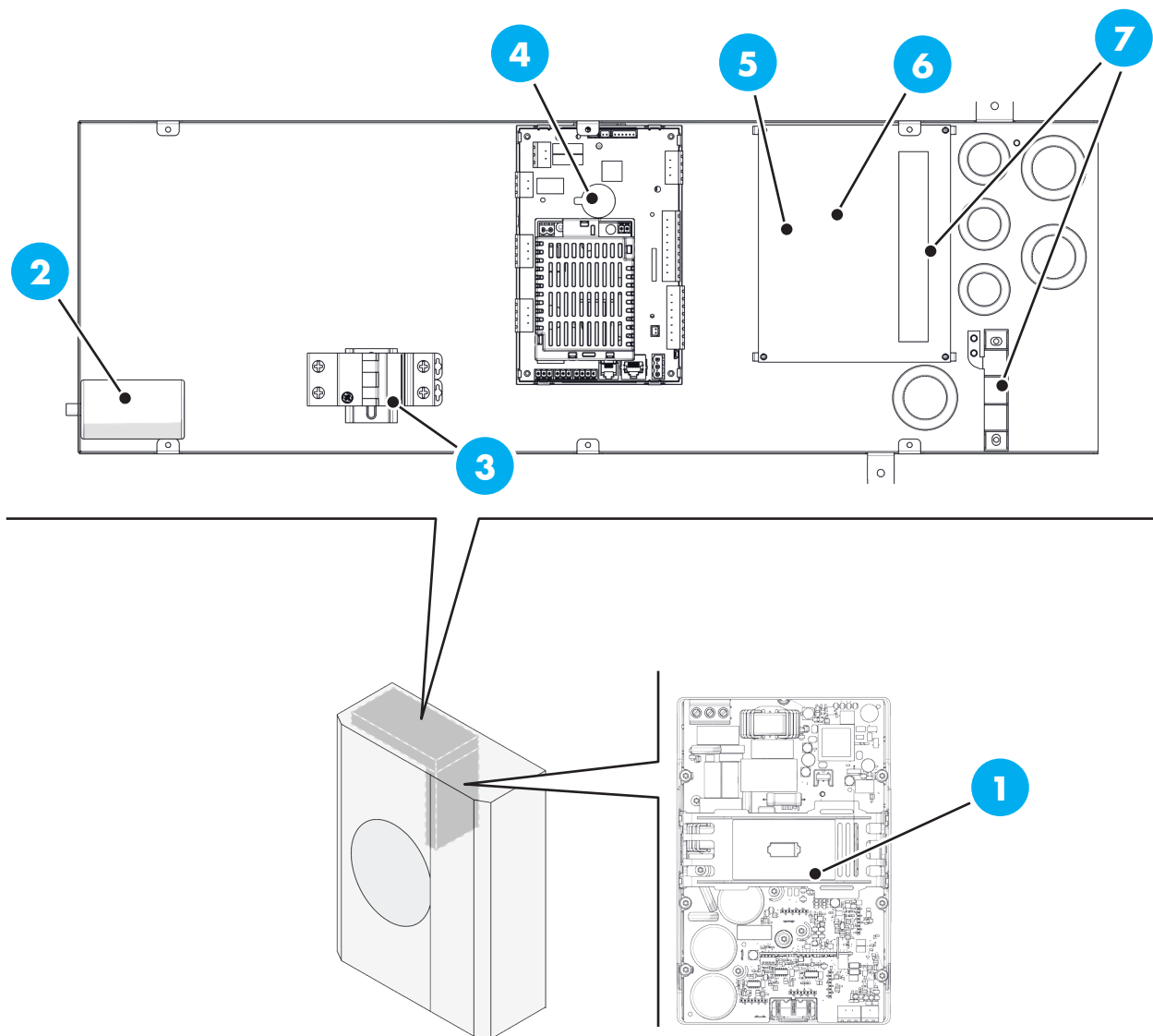

CONNECTIONS

1	A2 - Compressor inverter	6	Connector B
2	TC1	7	Connector C
3	QM1- Compressor thermal-magnetic circuit breaker	8	Connector D
4	A3	9	Fuse terminal blocks (FU1...FU6)
5	Connector A	10	User terminal blocks

FUSE PROTECTION TERMINAL BLOCK

9	FU1	Fan protection fuse
	FU2	Protection fuse for system circuit circulator
	FU3	Auxiliary circuit protection fuse 230 V
	FU4	Auxiliary circuit protection fuse 230 V
	FU5	Auxiliary circuit protection fuse 230 V
	FU6	Auxiliary circuit protection fuse 24 V

USER TERMINAL BLOCK

10	OP	
	L	Unit power connections
	N	
	1	NC: Alternative system water source enable
	2	NO: Alternative system water source enable
	3	C: Contact power supply
	4	
	5	Settable multifunction input.
	6	
	7	Domestic hot water storage probe
	8	
	9	Enable for alternative DHW source (230 V - 1 A max)
	10	
	11	3-Way valve enable (230 V - 1 A max)
	12	
13		
14	Unit display connection (A4)	
15		



4.14 Duct characteristics

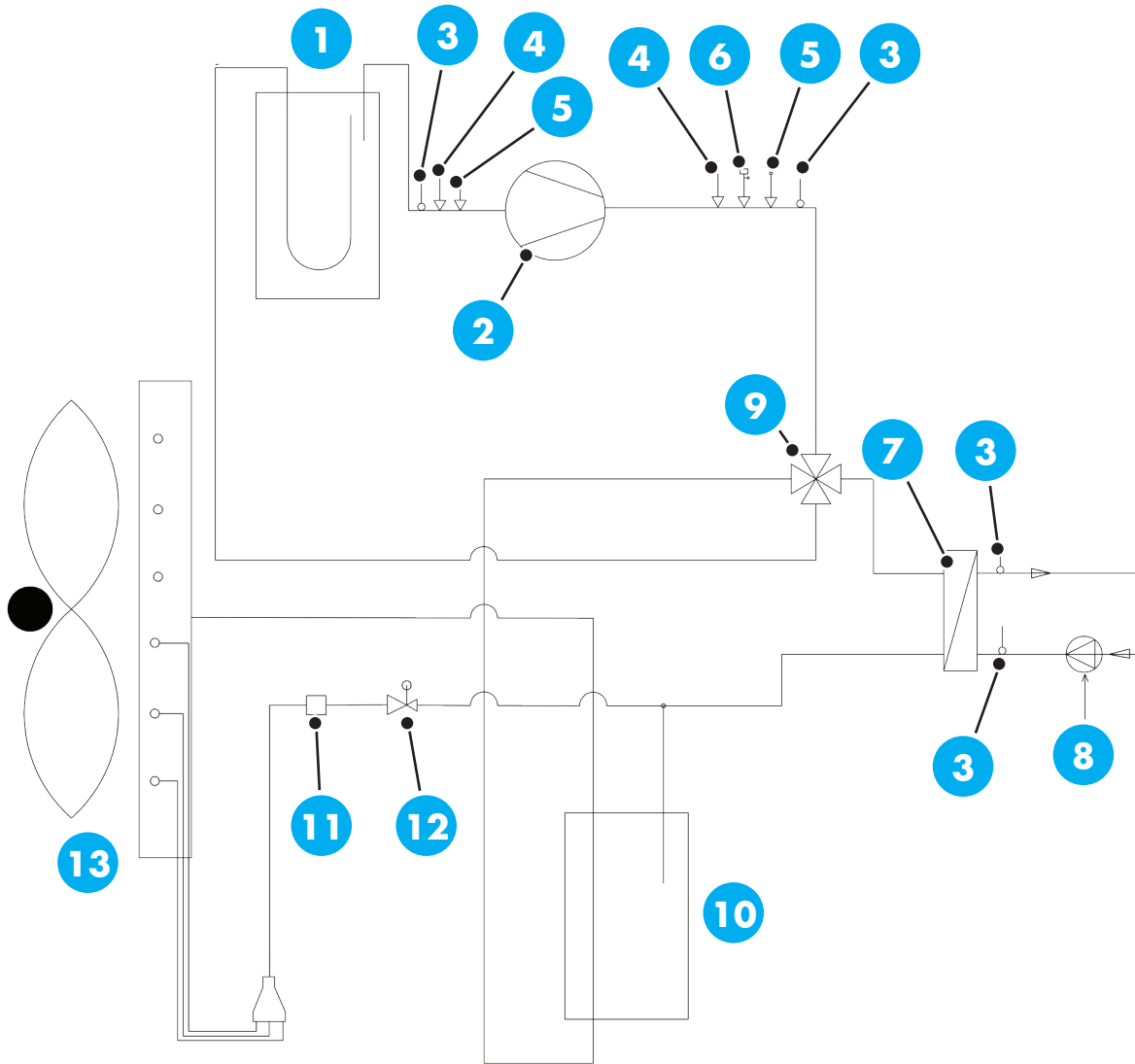

KEY

1	Gas separator	8	System circulator
2	Compressor	9	4-way valve
3	Temperature probe	10	Liquid receiver
4	Pressure transducer	11	Dehydrator filter
5	Filling valve	12	Electronic expansion valve
6	High pressure switch	13	Finned heat exchanger
7	System heat exchanger		

5 Commissioning

5.1 Preliminary checks

- Check the availability of diagrams and manuals of the installed machine.
- Check the availability of wiring and hydraulic diagrams of the system to which the machine is connected.
- Make sure the machine is placed on a perfectly level surface.
- Make sure that there are suitable condensate drain systems.
- Check the presence of vibration damping joints on the hydraulic pipes between the heat pump and the system.
- Check that the shut-off cocks of the hydraulic circuits are open.
- Check that the hydraulic system has been filled under pressure and vented.
- Check that the electrical and earthing connections are configured in accordance with the prevailing regulations in the machine installation country.
- Make sure that the electrical voltage is within the tolerance limit ($\pm 10\%$).
- Check that the case coils have been powered for at least 2 hours before starting.





Thermics Energie s.r.l.

**Registered Office and Operational Headquarters:
Via C. Pascoletti 2 - 33040 Povoletto (UD) Italy
Tel. (+39) 0432 823600 – Fax. (+39) 0432 825847
www.thermics-energie.it | info@thermics-energie.it**

All rights reserved. Thermics Energie reserves the right to modify and update this document